

This Generating Facility Interconnection Agreement (Multiple Tariff) (“Agreement”) is entered into by and between LA County Sanitation District (“Producer”), and Southern California Edison Company (“SCE”), a California corporation. Customer and SCE are sometimes also referred to in this Agreement jointly as “Parties” or individually as “Party.” In consideration of the mutual promises and obligations stated in this Agreement and its Appendices, the Parties agree as follows:

1. SCOPE AND PURPOSE

- 1.1 This Agreement provides for Producer to interconnect and operate a Generating Facility in parallel with SCE’s Distribution System to serve the electrical loads at the location identified in Section 2.4 (or for the qualifying energy where permitted under Section 218 of the California Public Utilities Code (“PUC”)). The Generating Facility may consist of any combination of (a) generator(s) for which Producer qualifies as an “eligible customer-generator” for Net Billing Tariff (NBT) or net energy metering (NEM) service pursuant to PUC Sections 2827 through 2827.10 (“Eligible Generator(s)”), and (b) other generator(s) (“Non-Eligible Generator(s)”). Pursuant to PUC Sections 2827 through 2827.10, an Eligible Generator can employ any of the following technologies: biomass, solar thermal, photovoltaic, wind, geothermal, fuel cells using renewable fuels, small hydroelectric generation, digester gas, municipal solid waste conversion, landfill gas, ocean wave, ocean thermal, or tidal current, and any additions or enhancements to the facility using that technology; or other fuel cells (pursuant to PUC Section 2827.10).
- 1.2 This Agreement provides for Producer to operate the Eligible Generator(s) pursuant to the provisions of Sections 2827 through 2827.10 of the California PUC and the applicable SCE tariffs for NBT or NEM. This Agreement also provides for Producer to operate its Non-Eligible Generator(s). This Agreement does not provide for retail electrical service by SCE to Producer. Such arrangements must be made separately between SCE and Producer.
- 1.3 This Agreement does not address Producer’s account billing and payment for energy consumption. For the Generating Facility as specified in Section 2 of this Agreement, please refer to the applicable SCE NBT or NEM tariff schedules for billing and payment protocol.

2. SUMMARY AND DESCRIPTION OF PRODUCER’S GENERATING FACILITY

- 2.1 A description of the Generating Facility, including a summary of its significant components and a single-line diagram showing the arrangement of how Producer’s Generating Facility and loads are interconnected with SCE’s Distribution System are attached hereto as Appendix A and incorporated herein by reference.
- 2.2 Generating Facility identification number: NST-312938 (Assigned by SCE).
- 2.3 Producer’s SCE service account number: 8001003390 (Assigned by SCE).
- 2.4 Name and address used by SCE to locate the electric service account(s) used to interconnect the Generating Facility with SCE’s Distribution System.

Name: LA County Sanitation District

Address: 39300 30<sup>th</sup> St. E. A

SCE Use Only

<b>8001003390</b>	<b>NST-312938</b>
-------------------	-------------------

**GENERATING FACILITY INTERCONNECTION AGREEMENT**

Multiple Tariffs  
LA COUNTY SANITATION DISTRICT  
NST-312938

---

City: Palmdale CA 93550

2.5 The Gross Nameplate Rating of the Generating Facility is:

2.5.1 Eligible Generator(s):

**Renewable Electrical Generating Facility**

Solar: 3,900 kW

Wind: \_\_\_\_\_ kW

Biomass: \_\_\_\_\_ kW

Solar Thermal: \_\_\_\_\_ kW

Geothermal: \_\_\_\_\_ kW

Fuel Cells Using Renewable Fuels: \_\_\_\_\_ kW

Small Hydroelectric Generators: \_\_\_\_\_ kW

Municipal Solid Waste Conversion: \_\_\_\_\_ kW

Landfill Gas: \_\_\_\_\_ kW

Ocean Wave: \_\_\_\_\_ kW

Ocean Thermal or Tidal Current: \_\_\_\_\_ kW

Digester Gas: \_\_\_\_\_ kW

**Non Renewable Electrical Generating Facility**

Biogas Digester: \_\_\_\_\_ kW

Fuel Cell: \_\_\_\_\_ kW

2.5.2 Non-Eligible Generator(s): 6,489.6 kW

2.5.3 Total **Gross** Nameplate Rating of the Generating Facility(ies): 10,389.6 kW

2.6 The **Net** Nameplate Rating of the Generating Facility is:

2.6.1 Eligible Generator(s):

**Renewable Electrical Generating Facility**

Solar: 3000 kW

Wind: \_\_\_\_\_ kW

Biomass: \_\_\_\_\_ kW

Solar Thermal: \_\_\_\_\_ kW

Geothermal: \_\_\_\_\_ kW

Fuel Cells Using Renewable Fuels: \_\_\_\_\_ kW

Small Hydroelectric Generators: \_\_\_\_\_ kW

Municipal Solid Waste Conversion: \_\_\_\_\_ kW

Landfill Gas: \_\_\_\_\_ kW

**GENERATING FACILITY INTERCONNECTION AGREEMENT**

Multiple Tariffs  
LA COUNTY SANITATION DISTRICT  
NST-312938

---

Ocean Wave: \_\_\_\_\_ kW

Ocean Thermal or Tidal Current: \_\_\_\_\_ kW

Digester Gas: \_\_\_\_\_ kW

**Non Renewable Electrical Generating Facility**

Biogas Digester: \_\_\_\_\_ kW

Fuel Cell: \_\_\_\_\_ kW

2.6.2 Non-Eligible Generator(s): 6,489.6 kW

2.6.3 Total **NET** Nameplate Rating of the Generating Facility(ies): 9,489.6 kW

2.7 The **maximum level of power** that may be exported by the Generating Facility to SCE's Distribution System is expected to be:

2.7.1 Eligible Generator(s):

**Renewable Electrical Generating Facility**

Solar: 3,000 kW

Wind: \_\_\_\_\_ kW

Biomass: \_\_\_\_\_ kW

Solar Thermal: \_\_\_\_\_ kW

Geothermal: \_\_\_\_\_ kW

Fuel Cells Using Renewable Fuels: \_\_\_\_\_ kW

Small Hydroelectric Generators: \_\_\_\_\_ kW

Municipal Solid Waste Conversion: \_\_\_\_\_ kW

Landfill Gas: \_\_\_\_\_ kW

Ocean Wave: \_\_\_\_\_ kW

Ocean Thermal or Tidal Current: \_\_\_\_\_ kW

Digester Gas: \_\_\_\_\_ kW

**Non Renewable Electrical Generating Facility**

Biogas Digester: \_\_\_\_\_ kW

Fuel Cell: \_\_\_\_\_ kW

2.7.2 Non-Eligible Generator(s): 0 kW

2.7.3 **Total maximum level of power** that may be exported by the Generating Facility: 3,000 kW

2.8 The Generating Facility's expected date of Parallel Operation is 7/1/2025. This expected date of Parallel Operation shall be within two years of the date of this Agreement.

2.9 For the purpose of securing the Competition Transition Charge exemption available under Section 372 of the California Public Utilities Code, Producer hereby declares that the portion of the Generating Facility that is generating in a combined heat and power mode

# GENERATING FACILITY INTERCONNECTION AGREEMENT

Multiple Tariffs  
LA COUNTY SANITATION DISTRICT  
NST-312938

---

does /  does not meet the requirements for Cogeneration as such term is used in Section 216.6 of the California Public Utilities Code. Not Applicable.

2.10 What applicable rate schedule, known as the “otherwise applicable tariff” will be selected for the NBT or NEM account(s): TOU-8E.

### 3. DOCUMENTS INCLUDED; DEFINED TERMS

3.1 This Agreement includes the following exhibits, which are specifically incorporated herein and made a part of this Agreement.

Appendix A - Description of Generating Facility and Single-Line Diagram (supplied by Producer).

Appendix B - Information concerning Electric Rules 2 and 21 and other selected rules and tariffs of SCE (supplied by SCE).

Appendix C - (Where Applicable) Additional Terms and Conditions for Projects Requiring Interconnection Facilities and/or Upgrades to SCE’s Distribution and/or Transmission System.

Appendix D - (When Applicable) A copy of an agreement addressing financing and ownership of facilities required for interconnection (Supplied by SCE).

Appendix E - (When Applicable) Producer’s warranty that the Generating Facility meets the requirements for a “Cogeneration” facility as defined in Section 216.6 of the California PUC.

Appendix F - (When Applicable) List of eligible service accounts, as defined in SCE’s Schedule BG-NEM or FC-NEM, to be included in NBT or NEM calculations.

Appendix G - (When Applicable) List of eligible service accounts, as defined in SCE’s Schedule NEM-ST, to be included in NEM Aggregation calculations.

Appendix H - (When Applicable) Producer warranty and verified equipment requirements applicable to Generating Facilities requesting interconnection pursuant to the provisions of the NBT or NEM successor tariffs (i.e., Schedule NBT or Schedule NEM-ST).

Appendix I - (When Applicable) Producer’s warranty that it meets the requirements for an Eligible Fuel Cell Customer-Generator and the Generating Facility is an Eligible Fuel Cell Electrical Generating Facility Pursuant to Section 2827.10 of the California Public Utilities Code.

Appendix J - (When Applicable) Net Billing Tariff Renewable Electrical Generating Facility Size Attestation

3.2 When initially capitalized, whether in the singular or in the plural, the terms used herein shall have the meanings assigned to them either in this Agreement or in SCE’s Electric

# GENERATING FACILITY INTERCONNECTION AGREEMENT

Multiple Tariffs  
LA COUNTY SANITATION DISTRICT  
NST-312938

---

Rule 1 or Electric Rule 21, Section C. If any term is defined in both Electric Rule 1 and Electric Rule 21, the definition in Rule 21 shall prevail.

## 4. TERM AND TERMINATION

4.1 This Agreement shall become effective as of the last date entered in Section 17 of this Agreement ("Effective Date"). This Agreement shall continue in full force and effect until the earliest date that one of the following events occurs:

- (a) The Parties agree in writing to terminate the Agreement; or
- (b) Unless otherwise agreed in writing by the Parties, at 12:01 A.M. on the day following the date the electric service account through which Producer's Generating Facility is interconnected to SCE's Distribution System is closed or terminated; or
- (c) At 12:01 A.M. on the 61<sup>st</sup> day after Producer or SCE provides written Notice pursuant to Section 9 of this Agreement to the other Party of Producer's or SCE's intent to terminate this Agreement.

4.2 Producer may elect to terminate this Agreement for any reason pursuant to the terms of Section 4.1(c). SCE may elect to terminate this Agreement pursuant to the terms of Section 4.1(c) for one or more of the following reasons:

- (a) A change in applicable tariffs as approved or directed by the California Public Utilities Commission ("Commission"), or a change in any local, state or federal law, statute or regulation, either of which materially alters or otherwise affects SCE's ability or obligation to perform SCE's duties under this Agreement; or
- (b) Unless otherwise agreed in writing by the Parties, Producer fails to take all corrective actions specified in SCE's Notice, within the timeframe set forth in such Notice, that Producer's Generating Facility is out of compliance with the terms of this Agreement; or
- (c) Producer fails to interconnect and operate the Generating Facility per the terms of this Agreement within 120 days of the date of Parallel Operation as set forth in Section 2.8 of this Agreement; or
- (d) Producer abandons the Generating Facility. SCE shall deem the Generating Facility to be abandoned if (i) SCE determines, in its sole opinion, that the Generating Facility is non-operational, (ii) SCE provides Producer with Notice of its intent to terminate this Agreement as a result of Producer's apparent abandonment of the Generating Facility, and (iii) Producer does not respond by affirming Producer's intent and ability to continue to operate the Generating Facility.
- (e) Producer makes a change to the physical configuration of the Generating Facility, as declared in Section 2 and Appendix A of this Agreement.

## GENERATING FACILITY INTERCONNECTION AGREEMENT

Multiple Tariffs

LA COUNTY SANITATION DISTRICT

NST-312938

---

- 4.3 Notwithstanding any other provisions of this Agreement, SCE shall have the right to unilaterally file with the Commission, pursuant to the Commission's rules and regulations, an application to terminate this Agreement.
- 4.4 Any agreements attached to and incorporated into this Agreement shall terminate concurrently with this Agreement unless the Parties have agreed otherwise in writing.

### 5. GENERATING FACILITY INTERCONNECTION AND OPERATING REQUIREMENTS

- 5.1 Producer is responsible for operating the Generating Facility in compliance with all of SCE's tariffs, including but not limited to SCE's Electric Rule 21, and any other regulations and laws governing the interconnection of the Generating Facility.
- 5.2 Producer shall be responsible for all applicable study costs as outlined in SCE's Electric Rule 21.
- 5.3 If the studies conducted pursuant to the applicable provisions of Electric Rule 21 result in the need for upgrades to SCE's Distribution and/or Transmission System, SCE shall be afforded the time necessary to complete those upgrades before issuing written approval allowing the Producer to operate the Generating Facility. Costs for those upgrades and any necessary Interconnection Facilities shall be borne by the Producer, pursuant to the terms and conditions outlined in Appendices C and D of this Agreement.
- 5.4 Unless otherwise agreed upon in writing by the Parties, this Agreement does not provide for, nor otherwise require SCE to purchase, transmit, distribute, or store the electrical energy produced by Producer's Generating Facility.
- 5.5 Except for that energy delivered to SCE through NBT or NEM, the electric power produced by Producer's Generating Facility shall be used solely to serve electrical loads connected to the electric service account that SCE uses to interconnect Producer's Generating Facility. Producer shall not use the Generating Facility to serve electrical loads that will cause Producer to be considered an "electrical corporation" as such term is used in Section 218 of the PUC.
- 5.6 Producer shall: (a) maintain the Generating Facility and Interconnection Facilities in a safe and prudent manner and in conformance with all applicable laws and regulations including, but not limited to, Section 5.1, and (b) obtain any governmental authorizations and permits required for the construction and operation of the Generating Facility and Interconnection Facilities. Producer shall reimburse SCE for any and all losses, damages, claims, penalties, or liability it incurs as a result of Producer's failure to obtain or maintain any governmental authorizations and permits required for construction and operation of Producer's Generating Facility.
- 5.7 Producer shall not commence Parallel Operation of the Generating Facility until SCE has provided express written approval. Such approval shall normally be provided per the timelines established by the applicable PUC or by Electric Rule 21. Such approval will be provided after SCE's receipt of: (1) a completed NBT or NEM Generating Facility Interconnection Application including all supporting documents and payments as described in the Application or Electric Rule 21; (2) any required NBT or NEM supplemental application forms; (3) a signed and completed Agreement; (4) a copy of Producer's final inspection clearance from the local authority having jurisdiction over the Generating Facility; and (5) submission of all applicable payments for reviews, studies, Interconnection

# GENERATING FACILITY INTERCONNECTION AGREEMENT

Multiple Tariffs

LA COUNTY SANITATION DISTRICT

NST-312938

---

Facilities, Distribution System Upgrades, and Network Upgrades, as applicable. Such approval will not be unreasonably withheld. SCE shall have the right to have representatives present at the Commissioning Test as defined in Electric Rule 21. Producer shall notify SCE at least five (5) days prior to initial testing.

- 5.8 In no event shall the delivery of the maximum electric power to SCE's Distribution System exceed the amount or other limitations specified in Section 2 and Appendix A of this Agreement. If Producer does not regulate its Generating Facility in compliance with the limitations set forth in this Agreement, SCE may require Producer to disconnect its Generating Facility from SCE's Distribution System until Producer demonstrates to SCE's sole satisfaction that Producer has taken adequate measures to regulate the output of its Generating Facility and control its deliveries of electric power to SCE. Further, should SCE determine that Producer's operation of the Generating Facility is causing an unsafe condition or is adversely affecting SCE's ability to utilize its Distribution System in any manner, even if Producer's deliveries of electric power to SCE's Distribution system are within the limitations specified in this Agreement, SCE may require Producer to temporarily or permanently reduce or cease deliveries of electric power to SCE's Distribution System. Producer's failure to comply with the terms of this Section shall constitute a material breach of this Agreement and SCE may initiate termination in accordance with the terms of Section 4.2(b).
- 5.9 Producer shall not deliver reactive power to SCE's Distribution System unless the Parties have agreed otherwise in writing.
- 5.10 The Generating Facility shall be operated with all of the Producer's Protective Functions in service whenever the Generating Facility is operated in parallel with SCE's Distribution System. Any deviation from these requirements may occur only when the Parties have agreed to such deviations in writing.
- 5.11 If Producer declares that its Generating Facility meets the requirements for "Cogeneration" as such term is used in Section 216.6 of the PUC (or successor definition of "Cogeneration") ("Cogeneration Requirement"), Producer warrants that, beginning on the date of Parallel Operation and continuing throughout the term of this Agreement, its Generating Facility shall continue to meet such Cogeneration Requirements, per Appendix E of this Agreement.
6. INTERCONNECTION FACILITIES, DISTRIBUTION UPGRADES AND NETWORK UPGRADES
- 6.1 Producer and/or SCE, as appropriate, shall provide Interconnection Facilities, Distribution Upgrades and Network Upgrades that adequately protect SCE's Distribution System, personnel, and other persons from damage or injury which may be caused by the operation of Producer's Generating Facility.
- 6.2 Producer shall be solely responsible for the costs, design, purchase, construction, operation, and maintenance of the Interconnection Facilities that Producer owns, as further outlined in Appendix C.
- 6.3 If the provisions of SCE's Electric Rule 21, or any other tariff approved by the Commission, require SCE to own and operate a portion of the Interconnection Facilities, Distribution Upgrades or Network Upgrade, Producer and SCE shall promptly execute an agreement that establishes and allocates responsibility for the design, installation, operation, maintenance, and ownership of the Interconnection Facilities, Distribution Upgrades and

# GENERATING FACILITY INTERCONNECTION AGREEMENT

Multiple Tariffs

LA COUNTY SANITATION DISTRICT

NST-312938

---

Network Upgrades. This agreement shall be attached to and made a part of this Agreement as Appendix D.

- 6.4 The Interconnection Facilities may include Net Generation Output Metering for determination of standby charges and applicable non-bypassable charges, and/or other meters required for SCE's administration and billing pursuant to SCE's NBT or NEM tariffs.

## 7. LIMITATION OF LIABILITY

Each Party's liability to the other Party for any loss, cost, claim, injury, liability, or expense, including reasonable attorney's fees, relating to or arising from any act or omission in its performance of this Agreement, shall be limited to the amount of direct damage actually incurred. In no event shall either Party be liable to the other Party for any indirect, special, consequential, or punitive damages of any kind whatsoever.

## 8. INSURANCE

- 8.1 In connection with Producer's performance of its duties and obligations under this Agreement, Producer shall maintain, during the term of this Agreement, general liability insurance with a limit of two million dollars (\$2,000,000) for each occurrence.

Such commercial general liability insurance shall include coverage for Premises-Operations and Contractual Liability.

- 8.2 The commercial general liability insurance required in Section 8.1 shall, by endorsement to the policy or within the policy general conditions itself, (a) include SCE as an additional insured; (b) contain a severability of interest clause or cross-liability clause; (c) provide that SCE shall not by reason of its inclusion as an additional insured incur liability to the insurance carrier for payment of premium for such insurance; (d) that coverage provided is primary and not in excess to or contributing with any insurance or self-insurance maintained by SCE; (e) waiver of subrogation shall be granted to SCE; and (f) provide for thirty (30) calendar days' written notice to SCE prior to cancellation, termination, alteration, or material change of such insurance.

- 8.3 [Intentionally Blank]

- 8.4 Producer agrees to furnish evidence of insurance (certificates of insurance and endorsements as appropriate) to SCE prior to Parallel Operation, and thereafter for each insurance policy renewal during the term of this Agreement. SCE shall have the right to inspect or obtain a copy of the original policy or policies of insurance.

- 8.5 If Producer is self-insured with an established record of self-insurance, Producer may comply with the following in lieu of Sections 8.1 through 8.2:

- (a) Producer shall provide to SCE, at least thirty (30) calendar days prior to the date of Parallel Operation, evidence of an acceptable plan to self-insure to a level of coverage equivalent to that required under Section 8.1.
- (b) If Producer ceases to self-insure to the level required hereunder, or if Producer is unable to provide continuing evidence of Producer's ability to self-insure, Producer agrees to immediately obtain the insurance coverage required under Section 8.1 and 8.2 above.



**GENERATING FACILITY INTERCONNECTION AGREEMENT**

Multiple Tariffs  
LA COUNTY SANITATION DISTRICT  
NST-312938

---

- 8.6 All insurance policies, certificates of insurance, statements of self-insurance, endorsements, cancellations, terminations, alterations, and material changes of such insurance shall be issued and submitted to the following:

Southern California Edison Company  
Attention: NBT Program Administrator  
SCE Customer Solar & Self Generation  
P.O. Box 800  
Rosemead, CA 91770

9. NOTICES

- 9.1 Any written notice, demand, or request required or authorized in connection with this Agreement (“Notice”) shall be deemed properly given if delivered in person or sent by first class mail, postage prepaid, to the person specified below:

If to SCE: Southern California Edison Company  
Attention: NBT Program Administrator  
SCE Customer Solar & Self Generation  
P.O. Box 800  
Rosemead, CA 91770

If to Producer: Name: Los Angeles County Sanitation Districts  
Attention: Energy Recovery Supervisor  
Address: 1955 Workman Mill Road  
City: Whitter, CA 90601  
Phone: ( )  
Email: energyrecovery-supervisor.lacsd.org

- 9.2 A Party may change its address for Notice at any time by providing the other Party Notice of the change in accordance with Section 9.1.
- 9.3 The Parties may also designate operating representatives to conduct the daily communications, which may be necessary or convenient for the administration of this Agreement. Such designations, including names, addresses, and phone numbers may be communicated or revised by one Party’s Notice to the other.

10. REVIEW OF RECORDS AND DATA

- 10.1 SCE shall have the right to review and obtain copies of Producer’s operations and maintenance records, logs, or other information such as unit availability, maintenance outages, circuit breaker operation requiring manual reset, relay targets and unusual events pertaining to Producer’s Generating Facility or its interconnection with SCE’s Distribution System.
- 10.2 Producer authorizes SCE to release to the California Energy Commission (“CEC”) and/or the Commission information regarding the Generating Facility, including the Producer’s

# GENERATING FACILITY INTERCONNECTION AGREEMENT

Multiple Tariffs  
LA COUNTY SANITATION DISTRICT  
NST-312938

---

name and location, and the size, location and operational characteristics of the Generating Facility, as requested or required from time to time pursuant to the CEC's or Commission's rules and regulations.

## 11. ASSIGNMENT

This Agreement shall not be assigned if such assignment would cause the Eligible Generator(s) to not comply with the provisions of PUC Sections 2827 through 2827.10. Producer shall not voluntarily assign its rights or delegate its duties under this Agreement without SCE's written consent. Any assignment or delegation Producer makes without SCE's written consent shall not be valid. SCE shall not unreasonably withhold its consent to Producer's assignment of this Agreement.

## 12. NON-WAIVER

None of the provisions of this Agreement shall be considered waived by a Party unless such waiver is given in writing. The failure of a Party to insist in any one or more instances upon strict performance of any of the provisions of this Agreement or to take advantage of any of its rights hereunder shall not be construed as a waiver of any such provisions or the relinquishment of any such rights for the future, but the same shall continue and remain in full force and effect.

## 13. GOVERNING LAW, JURISDICTION OF COMMISSION, INCLUSION OF SCE'S TARIFF SCHEDULES, DEFINED TERMS

13.1 This Agreement shall be interpreted, governed, and construed under the laws of the State of California as if executed and to be performed wholly within the State of California without giving effect to choice of law provisions that might apply to the law of a different jurisdiction.

13.2 This Agreement shall, at all times, be subject to such changes or modifications by the Commission as it may from time to time direct in the exercise of its jurisdiction.

13.3 The interconnection and services provided under this Agreement shall at all times be subject to the terms and conditions set forth in the tariffs applicable to the electric service provided by SCE. Copies of such tariffs are available at SCE's Internet site: [www.sce.com](http://www.sce.com) or by request to SCE and are incorporated into this Agreement by this reference.

13.4 Notwithstanding any other provisions of this Agreement, SCE shall have the right to unilaterally file with the Commission, pursuant to the Commission's rules and regulations, an application for change in tariffs, rates, charges, classification, service, or any agreement relating thereto.

## 14. AMENDMENT AND MODIFICATION

This Agreement can only be amended or modified by a written agreement signed by both Parties. SCE shall determine in its sole discretion whether prior Commission approval is required for such amendments or modifications.

## 15. TRANSITION PROVISIONS

Producers receiving service on the current NEM tariffs pursuant to PUC Section 2827 (i.e., Schedule NEM) prior to SCE reaching its NEM trigger level or July 1, 2017, whichever is earlier, are subject to the transition provisions as outlined in the applicable NEM rate schedule.

**GENERATING FACILITY INTERCONNECTION AGREEMENT**

Multiple Tariffs

**LA COUNTY SANITATION DISTRICT**

NST-312938

---

Producers receiving service on the successor NEM tariffs pursuant to PUC Section 2827.1 and Commission Decision 16-01-044 (i.e., Schedule NEM-ST) are subject to the transition provisions as outlined in the applicable NEM successor tariff rate schedule. Producers receiving service on the NBT pursuant to PUC Section 2827.1 and Commission Decision 22-12-056 (i.e., Schedule NBT) are subject to the transition provisions as outlined in Schedule NBT.

16. ENTIRE AGREEMENT

This Agreement, including any incorporated tariff schedules and rules, contains the entire agreement and understanding between the Parties, their agents, and employees as to the subject matter of this Agreement. Each party also represents that in entering into this Agreement, it has not relied on any promise, inducement, representation, warranty, agreement or other statement not set forth in this Agreement or in the incorporated tariff schedules and rules.

17. SIGNATURES

This Agreement may be executed in counterparts, and by electronic signature on the part of SCE and/or the Producer, and copies of a Party's signed signature page may be transmitted to the other Party by facsimile or other electronic means. Copies of the signature page so transmitted may be used for the purpose of enforcing the terms of this Agreement as though they were originals and will not be made inadmissible in any legal or regulatory proceeding concerning this Agreement on the basis of the Best Evidence Rule or similar rule of admissibility.

IN WITNESS WHEREOF, the Parties hereto have caused this Agreement to be executed by their duly authorized representatives. This Agreement is effective as of the last date set forth below.

**LA COUNTY SANITATION DISTRICT**

**SOUTHERN CALIFORNIA  
EDISON COMPANY**

By: \_\_\_\_\_

By: \_\_\_\_\_

Name:           Laura Bettencourt          

Name:           Marcus Lotto          

Title:           Chairperson,  
County Sanitation District No. 20          

Title:           Senior Manager, Grid  
Interconnections & Contract  
Development          

Date: \_\_\_\_\_

Date: \_\_\_\_\_

# GENERATING FACILITY INTERCONNECTION AGREEMENT

Multiple Tariffs  
LA COUNTY SANITATION DISTRICT  
NST-312938

---

## APPENDIX A

### DESCRIPTION OF GENERATING FACILITY AND SINGLE-LINE DIAGRAM

(Provided by Producer)

(Note: The Description of the Generating Facility should include, but not limited to, for each of the technology types of generation: spatial configuration, net and gross nameplate ratings, manufacturer, if the generators are certified under Electric Rule 21, protection equipment, and intended mode of operation (i.e. non-export; inadvertent export; and continuous export, where application). Additionally, points of interconnection with SCE, as well as locations and type of protection equipment and disconnect switches should be identified.)

1. **Generating Facility Description:** All equipment and facilities comprising the Producer's 9,489.6 net kW (10,389.6 gross kW) solar PV, diesel, and Battery Energy Storage System ("BESS") generating facility in Palmdale California, as disclosed by the Producer in its Application, which consists of (i) generating facilities described below, (ii) control system (i.e. Tesla Site Controller) to limit the output of the photovoltaic and BESS not to exceed 3.0 MW at POI, (iii) two (2) existing 10/14 MVA (OA/FA) 12.47/4.16 kV (delta-wye-grounded) customer owned transformers with an H-X impedance of 7.0% on a 10/14 MVA base, (iv) power factor correction equipment, as necessary, (v) the associated infrastructure, (vi) meters and metering equipment, and (vi) appurtenant equipment.
  - a) Eligible Generator(s):
    - i. A new 3000 net kW solar generator which consists of: twenty-six (26) new SMA Sunny Highpower PEAK3 150-US (600V) inverters each rated at 150 kVA for a total maximum output of 3,900 kW at unity power factor.
  - b) Non-Eligible Generator(s):
    - i. A new 489.6 kW net output (0.489.6 gross output) energy storage generator which consists of: one (1) new Tesla Megapack 2 XL Energy Storage system with a four-hour rating of 489 kW/550 kVA/1958 kWh.
    - ii. An existing 6,000 kW net output (6000 gross output) diesel generator which consists of: three (3) CAT 3516C diesel generators each rated for 2.0 MVA. This existing diesel generating facility was interconnected pursuant to the Generating Facility Interconnection Agreement ("GFIA") for GFID2812 entered into by the Producer and SCE on February 20, 2014.
  - c) Termination of old contract and succession of new contract.

The Parties agree that, upon execution of the Agreement, the Agreement shall succeed the existing Rule 21 GFIA and associated Interconnection Facilities Financing and Ownership Agreement ("IFFOA") for GFID2812 between Producer and SCE, entered into on February 20, 2014. The GFIA and IFFOA for GFID2812 shall be terminated on the date the Agreement is fully executed.

## GENERATING FACILITY INTERCONNECTION AGREEMENT

Multiple Tariffs  
LA COUNTY SANITATION DISTRICT  
NST-312938

---

As described above, one (1) of the Producer's Generating Facilities is a 489.6 kW Battery Energy Storage System ("BESS") and it is intended to be used for peak shaving service.

The Producer has represented in its Application that the operating characteristics of the BESS will be:

**Intended use:** Peak Shaving

**Electrical Load Function of Energy Storage System:**

- Rated Charging Demand (Load): 489.6 kW
- Maximum Charging Demand, if different than Rated Charging Demand: 489.6 kW
- If charging the storage system from the grid will increase the host facility's current peak load demand, provide the amount of added demand: 0

**Electrical Source Function of Energy Storage System:**

- Maximum Storage Capability: 1,984.4 kWh
- Rated constant Discharge: 489.6 kW
- Maximum Constant Discharge: 550 kW

The Application also describes the charging control system to limit peak load demand and the device(s) that will be used to limit the BESS's discharge.

Producer acknowledges and understands that this Agreement requires that the Generating Facility operate consistent with the above-described operating characteristics.

## 2. Single-Line Diagram:

# GENERATING FACILITY INTERCONNECTION AGREEMENT

Multiple Tariffs  
LA COUNTY SANITATION DISTRICT  
NST-312938

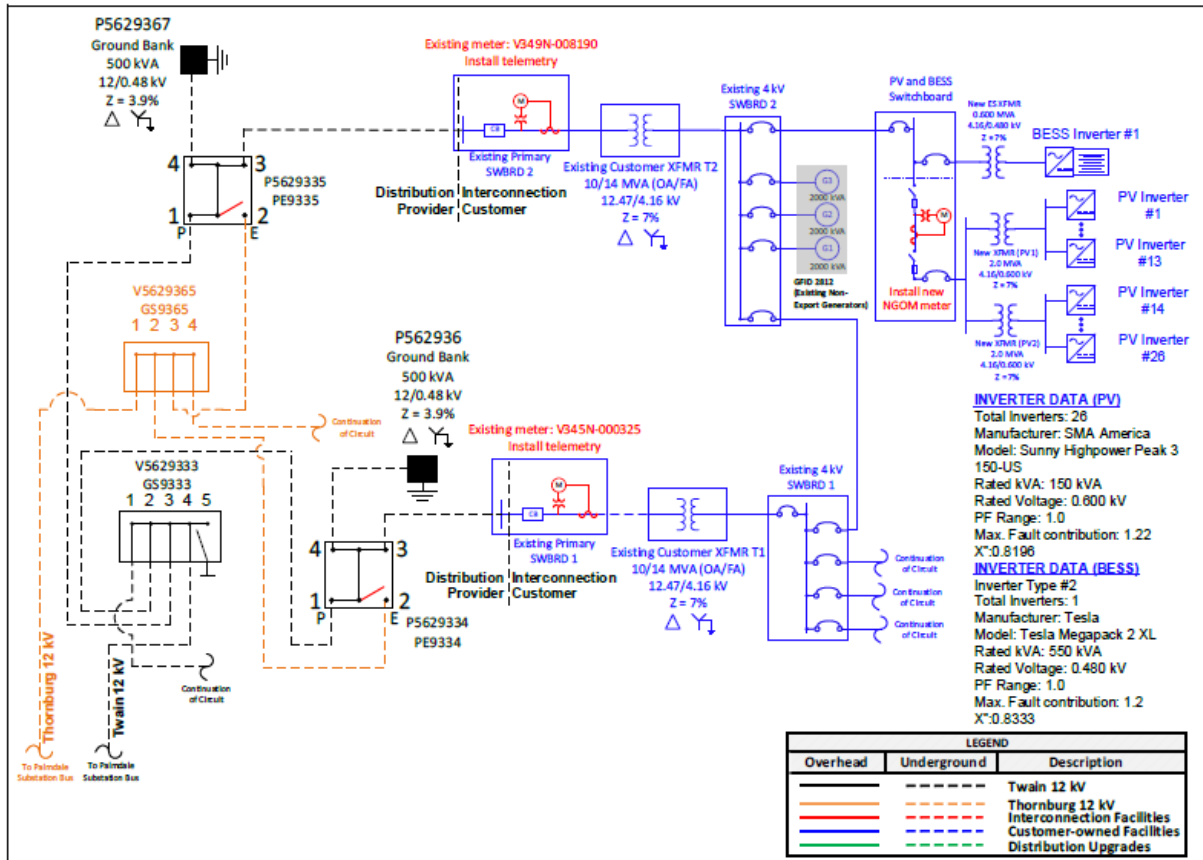

**GENERATING FACILITY INTERCONNECTION AGREEMENT**

Multiple Tariffs  
LA COUNTY SANITATION DISTRICT  
NST-312938

---

**APPENDIX B**

**Electric Rules “2” and “21”**

(Note: SCE's Electric Rules 2 and 21 may be subject to such changes or modifications by the Commission as the Commission may, from time to time, direct in the exercise of its jurisdiction. SCE's tariffs, including Rules 2 and 21 can be accessed via the SCE website at [www.sce.com/regulatory](http://www.sce.com/regulatory). Upon request, SCE can provide copies to Producer of Rules 2 and 21.)

**GENERATING FACILITY INTERCONNECTION AGREEMENT**

Multiple Tariffs

**LA COUNTY SANITATION DISTRICT**

NST-312938

---

**APPENDIX C**

Additional Terms and Conditions for Projects Requiring  
Interconnection Facilities and/or Upgrades to SCE's Distribution and/or Transmission System



# GENERATING FACILITY INTERCONNECTION AGREEMENT

Multiple Tariffs  
LA COUNTY SANITATION DISTRICT  
NST-312938

---

## Section 1. Cost Responsibility for Interconnection Facilities and Distribution Upgrades

### 1.1 Interconnection Facilities

- 1.1.1 The Producer shall pay for the cost of the Interconnection Facilities itemized in Appendix C-1 below and as provided, where applicable, in the Facilities Financing and Ownership Agreement (“FFOA”) incorporated as Appendix D below. SCE shall provide a best estimate cost, including a cost estimate pursuant to the Cost Envelope Option provisions of Rule 21, Section F.7, as applicable, including overheads and any applicable Income Tax Component of Contribution (ITCC), for the purchase and construction of its Interconnection Facilities and provide a detailed itemization of such costs. Costs associated with Interconnection Facilities may be shared with other entities that may benefit from such facilities by agreement of the Producer, such other entities, and SCE. Customers who elected the Cost Envelope Option will be subject to the provisions of Rule 21, Section F.7, as applicable, for the determination of actual costs.
- 1.1.2 The Producer shall be responsible for its share of all reasonable expenses, including overheads and any applicable ITCC, associated with (1) owning, operating, maintaining, repairing, and replacing its own Interconnection Facilities, and (2) operating, maintaining, repairing, and replacing SCE's Interconnection Facilities.

### 1.2 Distribution Upgrades

- 1.2.1 No portion of this Section 1.2 shall apply unless the interconnection of the Generating Facility requires Distribution Upgrades.
- 1.2.2 SCE shall design, procure, construct, install, and own the Distribution Upgrades described in Appendix C-2 below and as provided, where applicable, in the FFOA incorporated as Appendix D below. If SCE and the Producer agree, the Producer may construct Distribution Upgrades that are located on land owned by the Producer. The actual cost of the Distribution Upgrades, including overheads and any applicable ITCC, shall be directly assigned to the Producer. Customers who elected the Cost Envelope Option will be subject to the provisions of Rule 21, Section F.7, as applicable, for the determination of actual costs.

## Section 2. Cost Responsibility for Network Upgrades

### 2.1 Applicability

No portion of this Section 2 shall apply unless the interconnection of the Generating Facility requires Network Upgrades.

### 2.2 Network Upgrades

SCE shall design, procure, construct, install, and own the Network Upgrades described in Appendix C-2 below and as provided, where applicable, in the FFOA incorporated as Appendix D below. If SCE and the Producer agree, the Producer may construct Network Upgrades that are located on land owned by the Producer. Unless SCE elects to pay for Network Upgrades, the actual cost of the Network Upgrades, including overheads, shall be borne by the Producer unless Section 2.2.1 directs otherwise.

#### 2.2.1 Repayment of Amounts Advanced for Network Upgrades

To the extent that the CAISO Tariff, currently Section 14.3.2 of Appendix DD, provides for cash repayment to interconnection customers for contribution to the cost of Network Upgrades, the Producer shall be entitled to a cash repayment, equal to the total amount paid to SCE and Affected System operator, if any, for Network Upgrades, including any tax gross-up or other tax-related payments

# GENERATING FACILITY INTERCONNECTION AGREEMENT

Multiple Tariffs  
LA COUNTY SANITATION DISTRICT  
NST-312938

---

associated with the Network Upgrades, and not otherwise refunded to the Producer, to be paid to the Producer on a dollar-for-dollar basis for the non-usage sensitive portion of transmission charges, as payments are made under SCE's tariff and Affected System's tariff for transmission services with respect to the Generating Facility.

Any repayment shall include interest calculated in accordance with the methodology set forth in FERC's regulations at 18 C.F.R. §35.19a(a)(2)(iii) from the date of any payment for Network Upgrades through the date on which the Customer receives a repayment of such payment pursuant to this subparagraph. The Producer may assign such repayment rights to any person. To the extent that the CAISO Tariff does not provide for cash repayment to interconnection customers for contribution to the cost of Network Upgrades, Producer is not entitled to a cash repayment for amounts paid to SCE and Affected System operator for Network Upgrades, and no cash repayment shall be made pursuant to this Agreement.

2.2.1.1 If the Producer is entitled to a cash repayment pursuant to Section 2.2.1, the Producer, SCE, and any applicable Affected System operators may adopt any alternative payment schedule that is mutually agreeable so long as SCE and said Affected System operators take one of the following actions no later than five years from the Commercial Operation Date: (1) return to the Producer any amounts advanced for Network Upgrades not previously repaid, or (2) declare in writing that SCE or any applicable Affected System operators will continue to provide payments to the Producer on a dollar-for-dollar basis for the non-usage sensitive portion of transmission charges, or develop an alternative schedule that is mutually agreeable and provides for the return of all amounts advanced for Network Upgrades not previously repaid; however, full reimbursement shall not extend beyond twenty (20) years from the Commercial Operation Date.

2.2.1.2 If the Generating Facility fails to achieve commercial operation, but it or another generating facility is later constructed and requires use of the Network Upgrades, SCE and Affected System operator shall at that time reimburse the Producer for the amounts advanced for the Network Upgrades if the Producer is entitled to a cash repayment pursuant to Section 2.2.1. Before any such reimbursement can occur, the Producer, or the entity that ultimately constructs the generating facility, if different, is responsible for identifying the entity to which reimbursement must be made.

## 2.3 Rights Under Other Agreements

Notwithstanding any other provision of this Agreement, nothing herein shall be construed as relinquishing or foreclosing any rights, including but not limited to firm transmission rights, capacity rights, transmission congestion rights, or transmission credits, that the Producer shall be entitled to, now or in the future, under any other agreement or tariff as a result of, or otherwise associated with, the transmission capacity, if any, created by the Network Upgrades, including the right to obtain cash reimbursements or transmission credits for transmission service that is not associated with the Generating Facility.

# GENERATING FACILITY INTERCONNECTION AGREEMENT

Multiple Tariffs  
LA COUNTY SANITATION DISTRICT  
NST-312938

---

## Section 3. Billing, Payment, Milestones, and Financial Security

### 3.1 Billing and Payment Procedures

SCE shall bill the Producer for the design, engineering, construction, and procurement costs, including any applicable ITCC and/or other taxes, of Interconnection Facilities and Distribution and/or Network Upgrades contemplated by this Agreement pursuant to the FFOA, or as otherwise agreed by the Parties.

### 3.2 Milestones

The Parties shall agree on milestones for which each Party is responsible and list them in Appendix C-3 below. A Party's obligations under this provision may be extended by agreement. If a Party anticipates that it will be unable to meet a milestone for any reason other than a Uncontrollable Force Event, it shall immediately notify the other Party of the reason(s) for not meeting the milestone and (1) propose the earliest reasonable alternate date by which it can attain this and future milestones, and (2) requesting appropriate amendments to Appendix C-3 below. The Party affected by the failure to meet a milestone shall not unreasonably withhold agreement to such an amendment unless it will suffer significant uncompensated economic or operational harm from the delay, (2) attainment of the same milestone has previously been delayed, or (3) it has reason to believe that the delay in meeting the milestone is intentional or unwarranted notwithstanding the circumstances explained by the Party proposing the amendment.

### 3.3 Financial Security Arrangements

At least 20 Business Days prior to the commencement of the design, procurement, installation, or construction of a discrete portion of SCE's Interconnection Facilities and Distribution and/or Network Upgrades, the Producer shall provide SCE, at the Producer's option, a guarantee, a surety bond, letter of credit or other form of security that is reasonably acceptable to SCE and is consistent with the Uniform Commercial Code of the jurisdiction where the Point of Interconnection is located. Such security for payment shall be in an amount sufficient to cover the costs for constructing, designing, procuring, and installing the applicable portion of the SCE's Interconnection Facilities and Distribution and/or Network Upgrades and shall be reduced on a dollar-for-dollar basis for payments made to SCE under this Agreement during its term. In addition:

3.3.1 The guarantee must be made by an entity that meets the creditworthiness requirements of SCE, and contain terms and conditions that guarantee payment of any amount that may be due from the Producer, up to an agreed-to maximum amount.

3.3.2 The letter of credit or surety bond must be issued by a financial institution or insurer reasonably acceptable to SCE and must specify a reasonable expiration date.

## Section 4. Taxes

### 4.1 Applicable Tax Laws and Regulation

The Parties agree to follow all applicable tax laws and regulations, consistent with Commission policy and Internal Revenue Service requirements.

**GENERATING FACILITY INTERCONNECTION AGREEMENT**

Multiple Tariffs  
LA COUNTY SANITATION DISTRICT  
NST-312938

---

**4.2 Maintenance of Tax Status**

Each Party shall cooperate with the other to maintain the other Party's tax status. Nothing in this Agreement is intended to adversely affect SCE's tax exempt status with respect to the issuance of bonds including, but not limited to, local furnishing bonds.

**Section 5. Environmental Releases**

Each Party shall notify the other Party, first orally and then in writing, of the release of any hazardous substances, any asbestos or lead abatement activities, or any type of remediation activities related to the Generating Facility or the Interconnection Facilities, each of which may reasonably be expected to affect the other Party. The notifying Party shall (1) provide the notice as soon as practicable, provided such Party makes a good faith effort to provide the notice no later than 24 hours after such Party becomes aware of the occurrence, and (2) promptly furnish to the other Party copies of any publicly available reports filed with any governmental authorities addressing such events.

**Section 6. Subcontractors**

Nothing in this Agreement shall prevent a Party from utilizing the services of any subcontractor as it deems appropriate to perform its obligations under this Agreement; provided, however, that each Party shall require its subcontractors to comply with all applicable terms and conditions of this Agreement in providing such services and each Party shall remain primarily liable to the other Party for the performance of such subcontractor.

- 6.1 The creation of any subcontract relationship shall not relieve the hiring Party of any of its obligations under this Agreement. The hiring Party shall be fully responsible to the other Party for the acts or omissions of any subcontractor the hiring Party hires as if no subcontract had been made; provided, however, that in no event shall SCE be liable for the actions or inactions of the Producer or its subcontractors with respect to obligations of the Producer under this Agreement. Any applicable obligation imposed by this Agreement upon the hiring Party shall be equally binding upon, and shall be construed as having application to, any subcontractor of such Party.
- 6.2 The obligations under this article will not be limited in any way by any limitation of subcontractor's insurance.

**Section 7. Billing and Payment**

Billings and payments shall be sent to the addresses set out below:

Producer: Los Angeles County Sanitation Districts  
Attention: Energy Recovery Supervisor  
Address: 1955 Workman Mill Road  
City: Whittier State: CA Zip: 90601

SCE: Southern California Edison Company  
Attention: Accounts Receivable (GCM)  
Address: P.O. Box 800

**GENERATING FACILITY INTERCONNECTION AGREEMENT**

Multiple Tariffs

**LA COUNTY SANITATION DISTRICT**

NST-312938

---

City: Rosemead State: CA Zip: 91771-0001

# GENERATING FACILITY INTERCONNECTION AGREEMENT

Multiple Tariffs  
LA COUNTY SANITATION DISTRICT  
NST-312938

---

## Appendix C-1

### **Description and Costs of the Generating Facility, Interconnection Facilities, and Metering Equipment**

Equipment, including the Generating Facility, Interconnection Facilities, and metering equipment, shall be itemized and identified as being owned by the Producer or SCE. SCE will provide a best estimate itemized cost, including a cost estimate pursuant to the Cost Envelope Option provisions of Rule 21, Section F.7, if applicable, including overheads and any applicable ITCC, of its Interconnection Facilities and metering equipment, and a best estimate itemized cost of the annual operation and maintenance expenses associated with its Interconnection Facilities and metering equipment.

#### **1. Description of Generating Facility:**

See Appendix A to this Agreement.

#### **2. Description and Costs of Interconnection Facilities and Metering Equipment:**

See FFOA included as Appendix D to this Agreement.

**GENERATING FACILITY INTERCONNECTION AGREEMENT**

Multiple Tariffs  
LA COUNTY SANITATION DISTRICT  
NST-312938

---

**Appendix C-2**

**Description of Distribution and/or Network Upgrades and Cost Responsibility**

SCE shall describe the Distribution and/or Network Upgrades and provide an itemized best estimate of the cost, including a cost estimate pursuant to the Cost Envelope Option provisions of Rule 21, Section F.7, if applicable, including overheads and any applicable ITCC, of the Distribution and/or Network Upgrades and annual operation and maintenance expenses associated with such Distribution and/or Network Upgrades. SCE shall functionalize the upgrade costs and annual expenses as either transmission or distribution related.

**1. Description of Distribution Upgrades and Network Upgrades and Cost Responsibility:**

See FFOA included as Appendix D to this Agreement.

**GENERATING FACILITY INTERCONNECTION AGREEMENT**

Multiple Tariffs  
LA COUNTY SANITATION DISTRICT  
NST-312938

---

**Appendix C-3**

**Milestones**

In-Service Date: 6/31/2025

Critical milestones and responsibility as agreed to by the Parties:

	<b>Milestone</b>	<b>Date</b>	<b>Responsible Party</b>
(1)	Provide payment to SCE in accordance with Attachment A Section 1.F of Appendix D of the Agreement	Within twenty (20) business days of the Effective Date	Producer
(2)	Submit proof of insurance coverage in accordance with Section 8 of the Agreement	At least fifteen (15) calendar days prior to the date of initial Parallel Operation	Producer
(3)	Provide the following information ("Required Information") in support of SCE's engineering and design of SCE's Interconnection Facilities and Distribution Upgrades: 1) a completed SCE provided Producer information sheet, 2) a unique address for the project, 3) public right-of-way (street) base maps as required by the interconnection, 4) street improvement plans, 5) site plot plan on a 30:1 scale or digital file, 6) grading plans, 7) sewer and storm plot plans, 8) landscape, sprinkler and pedestal locations, 9) proposed location for the RTU, if applicable, 10) easements/lease agreements, and 11) panel drawings	Within thirty (30) calendar days after the effective date of this Agreement	Producer
(4)	Completion of SCE's design and engineering of SCE's Interconnection Facilities	Within ninety (90) calendar days of SCE's receipt of the Required Information	SCE
(5)	Provide to the Producer: 1) an updated scope of work and design for SCE's Interconnection Facilities; 2) an updated cost estimate and schedule related to SCE's Interconnection Facilities and Distribution Upgrades, as applicable, if there are any material changes resulting from completion of SCE's detailed design of SCE's Interconnection Facilities and Distribution Upgrades; and 3) comment on the Producer's proposed location for the RTU, if applicable	Within five (5) calendar days following completion of SCE's design and engineering of SCE's Interconnection Facilities, Distribution Upgrades, if applicable	SCE
(6)	Proposed Producer's Interconnection Facilities completion	6/1/2025	Producer



**GENERATING FACILITY INTERCONNECTION AGREEMENT**

Multiple Tariffs

LA COUNTY SANITATION DISTRICT

NST-312938

---

	<b>Milestone</b>	<b>Date</b>	<b>Responsible Party</b>
(7)	Completion of SCE's Interconnection Facilities	Within fifteen (15) months following the effective date of this Agreement and the FFOA, assuming milestones (2) and (5) of this Appendix C-3 have occurred timely*	SCE
(8)	Notification to SCE of completion of Commissioning Testing in accordance with Rule 21 Sections F.5 and L.5	At least fifteen (15) calendar days prior to the date of initial Parallel Operation	Producer
(9)	SCE's written authorization for initial Parallel Operation of the Generating Facility	At least ten (10) calendar days prior to the date of initial Parallel Operation and following Producer's satisfaction of Parallel Operation requirements pursuant to Rule 21	SCE
(10)	Expected date of initial Parallel Operation	7/1/2025	Producer

\* Note: Producer understands and acknowledges that such timeline is only an estimate and that equipment and material lead times, labor availability, outage coordination, regulatory approvals, right-of-way negotiations, or other unforeseen events could delay the actual in-service dates of SCE's Interconnection Facilities, or Distribution Upgrades beyond those specified.

Agreed to by:

For SCE: \_\_\_\_\_ Date: \_\_\_\_\_  
                  Marcus Lotto

For the Producer: \_\_\_\_\_ Date: \_\_\_\_\_  
                          Laura Bettencourt

**1. PARTIES:**

The Parties to this Facilities Financing and Ownership Agreement (FFOA) are, LA County Sanitation District (Producer), and Southern California Edison Company, (SCE). Producer and SCE are sometimes referred to herein individually as "Party," and collectively as "Parties."

**2. RECITALS:**

- 2.1 Producer has applied to interconnect a 10,389.6 kW (Gross Nameplate capacity) Generating Facility that will be operated in parallel with SCE's Distribution System. Said Generating Facility is described in Section 2 and Appendix A of the Generating Facility Interconnection Agreement ("GFIA") between the Parties to which this FFOA is attached. SCE has assigned the Generating Facility identification number NST-312938 to this facility.
- 2.2 The electrical facilities installed, owned, operated and maintained by SCE described in Attachment A, attached hereto, are required to interconnect Producer's Generating Facility to the SCE Distribution System pursuant to SCE's Rule 21. Such electrical facilities may include Interconnection Facilities, Distribution Upgrades and Network Upgrades.
- 2.3 Pursuant to SCE's Rule 21 all or a portion of the Interconnection Facilities, Distribution Upgrades and Network Upgrades are provided at the Producer's expense by SCE as "Added Facilities" as defined in SCE's Rule 2.H.

**3. AGREEMENT:**

The Parties agree as follows:

- 3.1 Unless otherwise defined herein, initially capitalized terms shall have the same meanings as defined in the GFIA or Section C of SCE's Rule 21. If any term is defined in both the GFIA and Rule 21, the definition in Rule 21 shall prevail.
- 3.2 The Parties agree to the arrangements as indicated in this Section 3.2 for the financing, design, installation, operation, maintenance, and ownership of the Interconnection Facilities, Distribution Upgrades and Network Upgrades described in Attachment A, attached hereto.
  - 3.2.1 SCE, at Producer's expense, shall install, own, operate, and maintain the Interconnection Facilities, Distribution Upgrades and Network Upgrades described as "Producer-Financed Added Facilities" in Attachment A, attached hereto.
  - 3.2.2 Producer shall finance, install, own, operate, and maintain the Interconnection Facilities described as "Producer-Constructed and Owned Interconnection Facilities" in Attachment A, attached hereto.

**4. TERM AND TERMINATION:**

- 4.1 This FFOA shall become effective as of the last date entered in Section 11 below. The FFOA shall continue in full force and effect until terminated by (1) either Party on at least thirty (30) days advance written notice or (2) the end of the 20-year term provided under Section 6.3(b) herein or (3) termination of the GFIA to which this FFOA is attached. Upon termination, Producer shall pay all costs and charges incurred to the date of termination pursuant to Section 8.9 herein, including but not limited to charges for engineering, surveying, right-of-way and easement acquisition expenses or any other expense incurred by SCE for the Producer, even if the Interconnection Facilities, Distribution Upgrades and Network Upgrades have not been installed.

4.2 Producer agrees to utilize the Interconnection Facilities, Distribution Upgrades and Network Upgrades described in Attachment A, attached hereto, in accordance with Prudent Electrical Practices. If Producer fails to so utilize said Interconnection Facilities, Distribution Upgrades and Network Upgrades, SCE may terminate this FFOA, remove the Interconnection Facilities, Distribution Upgrades and Network Upgrades, and Producer shall be subject to the Termination Charge pursuant to Section 8.9 herein.

**5. PROJECT DEVELOPMENT MILESTONES:**

Project development milestones, if applicable, are identified in Appendix C-3 of the GFIA.

**6. INTERCONNECTION FACILITIES, DISTRIBUTION UPGRADES AND NETWORK UPGRADES PROVIDED AS PRODUCER-FINANCED ADDED FACILITIES:**

The following shall apply for that portion of the Interconnection Facilities, Distribution Upgrades and Network Upgrades specified in Attachment A, attached hereto, as "Producer-Financed Added Facilities."

6.1 SCE shall, pursuant to SCE's Rule 21, engineer, design, procure equipment and materials, construct, install, own, operate, and maintain the Producer-Financed Added Facilities.

6.2 Producer shall pay to SCE in advance of construction, the estimated total Added Facilities Investment of said Producer-Financed Added Facilities, as set forth in Attachment A, attached hereto, as may be revised pursuant to Sections 8.2 and/or 8.3, herein. If applicable, said cost shall include the estimated Income Tax Component of Contributions (ITCC), pursuant to SCE's Preliminary Statement Part M as filed with the Commission and as may be revised from time to time.

6.3 In addition to the payment required under Section 6.2 herein, Producer shall pay to SCE an ownership charge determined as the product of (1) the total Added Facilities Investment in Producer-Financed Added Facilities as set forth in Attachment A, attached hereto, as may be revised pursuant to Sections 8.2 and/or 8.3 herein, and (2) the rate established for the replacement coverage option for "Producer-Financed Added Facilities" agreed to by the Parties as reflected in this Section 6.3 as set forth in SCE's Rule 2.H as filed with the Commission and as may be revised from time to time. Whenever Added Facilities are replaced, the Added Facilities Investment amount used as the basis for determining the ownership charge Producer pays SCE shall be subject to the conditions set forth in Section 8.6 or 8.7 herein. The replacement coverage option for Producer-Financed Added Facilities is as follows:

(a) Replacement Coverage into Perpetuity

Under this option, Producer shall pay to SCE, at SCE's sole option, either:

(1) A Monthly Charge determined by SCE based upon an initial monthly rate of **0.39%** times the total Added Facilities Investment amount; or,

(2) A One-Time Payment determined by SCE representing the present value of the sum of the Monthly Charges for the total Added Facilities Investment amount.

(b) Replacement Coverage with 20-Year Term

Under this Option, for a term of 20 years beginning with the date said Added Facilities are first made available for Producer's use, Producer shall pay to SCE a Monthly Charge determined by SCE based upon an initial monthly rate

of 0.32 % times the total Added Facilities Investment amount. At the end of the 20-year term, this FFOA shall terminate. If the Producer elects to continue to utilize the Added Facilities past the term of this FFOA, Producer and SCE must execute a new Added Facilities agreement without replacement coverage or with replacement coverage in perpetuity pursuant to the provision in SCE's Rule 2 Section H.2.f.(3).

(c) Without Replacement Coverage

Under this option, Producer shall pay SCE a Monthly Charge determined by SCE based upon an initial monthly rate of 0.29 % times the total Added Facilities Investment amount.

**7. INTERCONNECTION FACILITIES PROVIDED AS PRODUCER-CONSTRUCTED AND OWNED INTERCONNECTION FACILITIES:**

For that portion of the Interconnection Facilities specified in Attachment A, attached hereto, as "Producer-Constructed and Owned Interconnection Facilities", the Producer is subject to the following:

- 7.1 At Producer's expense, Producer shall finance, engineer, design, acquire equipment and materials, construct, obtain rights-of-way as necessary, install, own, lease or rent, operate, and maintain the Producer-Constructed and Owned Interconnection Facilities. The Producer-Constructed and Owned Interconnection Facilities shall be engineered, designed and constructed to be compatible with SCE's Interconnection Facilities, Distribution Upgrades and Network Upgrades, and in accordance with SCE's Rule 21, as applicable.
- 7.2 SCE shall, at Producer's expense, review Producer's design and require modifications that SCE reasonably determines necessary to assure compatibility with SCE's electrical system and assure SCE system integrity.
- 7.3 Producer shall notify SCE at least thirty (30) days prior to the Parallel Operation of Producer's Generating Facility and SCE shall have the right to inspect the Producer-Constructed and Owned Interconnection Facilities and shall notify Producer of any deficiencies within five (5) days after inspection. Producer must correct any deficiencies prior to Parallel Operation of the Generating Facility.

**8. INTERCONNECTION FACILITIES, DISTRIBUTION UPGRADES AND NETWORK UPGRADES BILLING:**

- 8.1 Producer shall pay to SCE in advance of any construction by SCE, any one-time costs (including, when applicable, the ITCC to rearrange existing facilities and/or to provide facilities normally installed by the Producer as set forth in Attachment A, attached hereto, as "One-Time Costs."
- 8.2 Unless otherwise agreed in writing, the costs and charges paid by Producer pursuant to Sections 6.2, 6.3, 7.2, 8.1, and 8.9 herein shall initially be based upon estimated costs. When the recorded book costs have been determined by SCE, the costs and charges paid by Producer under this FFOA shall be revised to be based upon such recorded costs and adjusted retroactively to the date when service was first available by means of such Added Facilities. By executing this FFOA, Producer has been informed and understands SCE's determination of recorded book cost may be delayed and that unless otherwise agreed, retroactive adjustments resulting from such determination may occur at anytime during the term of this FFOA. All amounts billed under this FFOA, unless other terms are mutually agreed upon, shall be payable to SCE within thirty (30) days from the date of presentation of a bill. Any credits resulting from such adjustments will, unless other terms are mutually agreed upon, be refunded to Producer.

APPENDIX D  
FACILITIES FINANCING AND OWNERSHIP AGREEMENT  
SOUTHERN CALIFORNIA EDISON COMPANY  
**LA COUNTY SANITATION DISTRICT**  
NST-312938

---

- 8.3 SCE shall have the right to revise the initial estimated costs and bill Producer using such revised estimated costs during the period preceding determination of the recorded book costs. SCE shall indicate such revisions on Attachment A, attached hereto, or a superseding Attachment A and provide a copy to Producer. SCE shall commence billing the costs and charges paid by Producer pursuant to this FFOA using such revised estimate not earlier than thirty (30) days from the date the revised estimate is provided to Producer.
- 8.4 Whenever the ownership charge is to be paid by Producer as a Monthly Charge pursuant to Section 6.3 herein, the Monthly Charge shall automatically increase or decrease without formal amendment to this FFOA if the Commission subsequently authorizes a higher or lower percentage rate in the calculation of the costs of ownership for Added Facilities as stated in SCE's Rule 2.H, effective with the date of such authorization.
- 8.5 If it becomes necessary for SCE to alter or rearrange the Added Facilities including, but not limited to, the conversion of overhead facilities to underground, Producer shall be notified of such necessity and shall be given the option to either terminate this FFOA in accordance with Sections 4 and 8.9 herein, or to pay to SCE additional amounts consisting of:
- (a) Revised costs and charges based on the total net additional installed cost of all new and remaining Added Facilities. Such revised costs and charges shall be determined, as applicable, in the same manner as described in Sections 6.2 and 6.3 herein; plus
  - (b) An additional payment of ITCC, and/or one-time cost, if any, for any new Added Facilities which shall be determined in the same manner as described in Sections 6.2 and 8.1 herein; plus
  - (c) The cost to remove any portion of the Added Facilities that are no longer necessary because of alteration or rearrangement, such charge is to be determined by SCE in the same manner as described in Section 8.9 herein.
- 8.6 Whenever Added Facilities are replaced due to damage (caused by other than the Producer's intentional or negligent conduct) or equipment failure and replacement coverage is provided pursuant to Sections 6.3(a) or (b) herein, such replacement will be at SCE's expense with no change in the Added Facilities Investment amount.
- 8.7 Whenever Added Facilities are replaced (1) due to damage or equipment failure and replacement coverage is not provided pursuant to Section 6.3(c) herein, or (2) due to Producer's increased load or generation levels, as determined by SCE, or (3) Producer's intentional or negligent conduct, such replacement will be made by SCE at the Producer's expense, including any applicable ITCC. Any additional amounts due to SCE as a result of such replacement shall be payable by the Producer to SCE within thirty (30) days from the date of presentation of a bill. If such replacement results in a change in the Added Facilities Investment, the Monthly Charge will be adjusted based on the revised added investment amount effective with the date the replaced Added Facilities are first available for Producer's use. Except that, where the replacement of Added Facilities is solely required for SCE's operating convenience or necessity or because of damage caused by the sole negligence or willful act of SCE, no increase shall be made in the Added Facilities Investment amount or the Monthly Charge.
- 8.8 Except as otherwise provided in this FFOA, SCE shall have the right to charge Producer under the terms and conditions of this FFOA commencing with the date SCE, in its sole opinion, determines the Added Facilities are available for Producer's use.
- 8.9 Upon discontinuance of the use of any Added Facilities due to termination of service, termination of this FFOA, or otherwise:

- (a) Producer shall pay to SCE on demand (in addition to all other moneys to which SCE may be legally entitled by virtue of such termination) a Termination Charge defined as the removal cost less the salvage value of the Added Facilities to be removed. Commencing in the sixteenth (16) year after the date service is first rendered by means of said Added Facilities, 20 percent of the Termination Charge shall be subtracted from that charge each year until the total charge is zero.
  - (b) SCE shall be entitled to remove and shall have a reasonable time in which to remove any portion of the Added Facilities located on the Producer's property.
  - (c) SCE may, at its option, alter, rearrange, convey, or retain in place any portion of the Added Facilities located on property other than Producer's property. Where all or any portion of the Added Facilities located on property other than Producer's property are retained in place and used by SCE to provide permanent service to other customers, the facility Termination Charge described in Section 8.9(a), herein, shall be reduced by the recorded installed cost of the retained facilities.
- 8.10 Producer shall not be required to pay the Termination Charge specified in Section 8.9, herein if termination of the use of the Added Facilities is caused solely by SCE. Termination pursuant to Section 4.2 herein or Section 4.1 of the GFIA shall be deemed not to have been caused solely by SCE.
- 8.11 Should any amount billed pursuant to this FFOA not be paid by Producer, SCE shall at any time be entitled to collect such amounts through an offset against any amount SCE may owe to Producer.

**9. GENERAL PROVISIONS:**

- 9.1 Unless otherwise provided for in this FFOA, Interconnection Facilities connected to SCE's side of the Point of Common Coupling, Distribution Upgrades and Network Upgrades shall be provided, installed, owned, and maintained by SCE at Producer's expense in accordance with SCE's Rule 21.
- 9.2 SCE shall not be obligated to begin construction of Added Facilities prior to Producer's payment of all moneys due as described in Sections 6.2, 6.3, 8.1, and 8.9 herein.
- 9.3 Where it is necessary to install Added Facilities on Producer's property, Producer hereby grants to SCE (a) the right to make such installation on Producer's property including installation of a line extension along the shortest practical route thereon and (b) the right of ingress to and egress from Producer's property as determined by SCE in its sole discretion for any purpose connected with the operation and maintenance of the Added Facilities. Producer shall provide rights-of-way or easements of sufficient space to provide legal clearance from all structures now or hereafter erected on Producer's property for any facilities of SCE.
- 9.4 Where formal rights-of-way or easements are required in, on, under, or over Producer's property or the property of others for the installation of the Added Facilities, SCE shall not be obligated to install the Added Facilities unless and until any necessary permanent rights-of-way or easements, satisfactory to SCE, are granted without cost to SCE. Upon termination of this FFOA in accordance with Section 4, SCE shall quitclaim all easements and rights of way in, on, under, and over Producer's property, which are, as determined by SCE in its sole discretion, no longer required by SCE due to the removal of its Added Facilities.

- 9.5 SCE shall not be responsible for any delay in completion of the installation of the Added Facilities including, but not limited to, delays resulting from shortage of labor or materials, strike, labor disturbances, war, riot, weather conditions, governmental rule, regulation, or order, including orders or judgments of any court or commission, delay in obtaining necessary rights-of-way and easements, act of God, or any other cause or condition beyond control of SCE. SCE shall have the right in the event it is unable to obtain materials or labor for all of its construction requirements, to allocate materials and labor to construction projects which it deems, in its sole discretion, most important to serve the needs of its customers, and any delay in construction hereunder resulting from such allocation shall be deemed to be a cause beyond SCE's control.
- 9.6 SCE shall not be liable for any loss, damage, or injury arising from SCE's installation, operation, maintenance, or control of the Added Facilities, unless such loss, damage, or injury results from SCE's sole negligence, and, in no event, shall SCE be liable for loss of profits, revenues, or other consequential damages. No adjustment shall be made to reduce billings if damages to, or malfunction of the Added Facilities results from any cause other than the negligence or willful act of SCE.
- 9.7 Added Facilities provided hereunder shall at all times remain the property of SCE.
- 9.8 This FFOA supplements the appropriate application and contract(s) for electric service presently in effect between the Parties.
- 9.9 Producer may assign this FFOA only with SCE's written consent. Such consent shall not be unreasonably withheld. Such assignment shall be deemed to include, unless otherwise specified therein, all of Producer's rights to any refunds, which might become due upon discontinuance of the use of any Added Facilities.

**10. GOVERNING LAW**

This FFOA shall be interpreted, governed, and construed under the laws of the State of California as if executed and to be performed wholly within the State of California and shall, to the extent provided by law, at all times be subject to applicable tariff rules and modification of such rules as directed by the Commission in the exercise of its jurisdiction.

**11. SIGNATURES**

This FFOA may be executed in counterparts, and by Electronic Signature on the part of SCE and/or the Producer, and copies of a Party's signed signature page may be transmitted to the other Party by facsimile or other electronic means. Copies of the signature page so transmitted may be used for the purpose of enforcing the terms of this FFOA as though they were originals and will not be made inadmissible in any legal or regulatory proceeding concerning this FFOA on the basis of the Best Evidence Rule or similar rule of admissibility.

IN WITNESS WHEREOF, the Parties hereto have caused this FFOA to be executed by their duly authorized representatives. This FFOA is effective as provided in Section 4.1 above.

**LA COUNTY SANITATION DISTRICT**

**SOUTHERN CALIFORNIA  
EDISON COMPANY**

By: \_\_\_\_\_

By: \_\_\_\_\_

Name:                     Laura Bettencourt                    

Name:                     Marcus Lotto

APPENDIX D  
FACILITIES FINANCING AND OWNERSHIP AGREEMENT  
SOUTHERN CALIFORNIA EDISON COMPANY  
**LA COUNTY SANITATION DISTRICT**  
NST-312938

---

Title: \_\_\_\_\_  
Chairperson, Board of  
Directors

Title: \_\_\_\_\_  
Senior Manager, Grid  
Interconnections & Contract  
Development

Date: \_\_\_\_\_

Date: \_\_\_\_\_



ATTACHMENT A TO APPENDIX D  
 FACILITIES FINANCING AND OWNERSHIP AGREEMENT  
 SOUTHERN CALIFORNIA EDISON COMPANY  
**LA COUNTY SANITATION DISTRICT**  
 NST-312938

**1. Added Facilities Investment for Producer- Financed Facilities**  
 (Provided per Section 3.2.1)

	<b>Component</b>	<b>Original Estimate</b>	<b>Revised Estimate</b>	<b>Recorded Cost</b>
A1.	<b>Interconnection Facilities (Existing Facilities)</b> <ul style="list-style-type: none"> <li>• 2 – 500 kVa ground padmount transformers.</li> <li>• 2 – 400/5 current transformers.</li> <li>• 100 feet – 3-1/c 12 kV primary cable.</li> </ul>	\$55,000.00 (Paid and installed under GFID2812)		\$55,000.00
A2.	<b>Interconnection Facilities (New Facilities)</b> <ul style="list-style-type: none"> <li>• Install bi-directional metering for meter V349N-008190 and meter V345N-000325</li> <li>• Install a Net Generation Output Meter (NGOM) or equivalent for the PV system.</li> </ul>	\$42,100.00		
B.	<b>Total Added Facilities Investment</b>	<b>\$97,100.00</b>		
C1.	<b>Income Tax Component of Contribution (ITCC) (Existing Facilities)</b> (A1. x 35%)	\$19,250.00 (Paid under GFID2812)		
C2.	<b>Income Tax Component of Contribution (ITCC) (New Facilities)</b> (A2. x 24%) (eff. 1/1/2018)	\$10,104.00		

ATTACHMENT A TO APPENDIX D  
 FACILITIES FINANCING AND OWNERSHIP AGREEMENT  
 SOUTHERN CALIFORNIA EDISON COMPANY  
**LA COUNTY SANITATION DISTRICT**  
 NST-312938

D.1	<b>One-Time Costs (Existing Facilities)</b>  Telemetry <sup>1</sup> - Centralized RTU or as required by the utility	\$6,100.00 <sup>2</sup> (Paid under GFID2812)		\$6,100.00
D.2	<b>One-Time Costs (New Facilities)</b>  Telemetry – Centralized RTU or as required by utility (footnotes under D.1 apply as well)	\$6,100.00		
E.1	<b>One-Time Payment</b> representing the present value of the sum of the Monthly Charges for the Added Facilities Investment amount shown in Row A.1 above pursuant to Section 6.3(a)(2) of this FFOA. $((\$55,000.00 \times 82.74\%)^n]$	\$45,507.00 (Paid under GFID2812)		\$45,507.00
E.2	Producer shall pay to SCE a <b>Monthly Charge</b> determined by SCE based upon an initial monthly rate of <b>0.29%</b> times the Added Facilities Investment amount shown in Row A2. above pursuant to Section 6.3 of this FFOA. $((\$42,100) \times 0.29\%)$	\$164.19		
<b>F.</b>	<b>Total Amount to be Advanced by Producer (A2. + C2. + D2)</b>	<b>\$58,304.00</b>		

**2. Description of Producer - Constructed and Owned Facilities (Provided per Section 3.2.2)**

Interconnection Facilities Component
a. All generating unit protective relays, controls and switchgear in compliance with SCE's Rule 21 and Electrical Service Requirements (ESR).

Note: Cost information need not be provided for Producer-Constructed and Owned Facilities.

<sup>1</sup> SCE acknowledges that the telemetry upgrades required for this project will not be in place as of the execution of this FFOA. Without waiving Producer's obligation to meet the telemetry requirements listed above in Item D, SCE agrees to allow the Generating Facility to be interconnected while the required telemetry upgrades are completed.

<sup>2</sup> Cost estimate is based on the use of a centralized RTU; should SCE subsequently determine that a centralized RTU cannot be utilized, the cost to provide the required telemetry may be significantly higher and the Producer will be notified in accordance with Sections 8.3 and 8.5 of this FFOA.

ATTACHMENT A TO APPENDIX D  
FACILITIES FINANCING AND OWNERSHIP AGREEMENT  
SOUTHERN CALIFORNIA EDISON COMPANY  
**LA COUNTY SANITATION DISTRICT**  
NST-312938

---

3. **Financial Security** Not applicable. Producer will provide full payment for the amounts identified in Section 1 of this Attachment A in accordance with Section 6.2 of the FFOA.

**GENERATING FACILITY INTERCONNECTION AGREEMENT**

Multiple Tariffs  
LA COUNTY SANITATION DISTRICT  
NST-312938

---

**APPENDIX E**  
(When Applicable)

**PRODUCER'S WARRANTY THAT THE GENERATING FACILITY IS A "COGENERATION" FACILITY  
PURSUANT TO SECTION 216.6 OF THE CALIFORNIA PUBLIC UTILITIES CODE**

This Appendix E is Not Applicable

For the purpose of securing the Competition Transition Charge exemption available under Section 372 of the California Public Utilities Code, Producer hereby declares that the Generating Facility meets the requirements for "Cogeneration" as such term is used in Section 216.6 of the California Public Utilities Code ("Cogeneration Requirements").

Producer warrants that, beginning on the date of Parallel Operation and continuing throughout the term of this Agreement, its Generating Facility shall continue to meet the Cogeneration Requirements. If Producer becomes aware that the Generating Facility has ceased to meet the Cogeneration Requirements, Producer shall promptly provide SCE with Notice of such change pursuant to Section 9.1 of the Agreement. If at any time during the term of this Agreement SCE determines in its sole discretion that Producer's Generating Facility may no longer meet the Cogeneration Requirements, SCE may require Producer to provide evidence that the Generating Facility continues to meet the Cogeneration Requirements, within 15 business days of SCE's request for such evidence. Additionally, SCE may periodically (typically, once per year) inspect Producer's Generating Facility and/or require documentation from Producer to monitor the Generating Facility's compliance with the Cogeneration Requirements. If SCE determines in its sole judgment that Producer either failed to provide evidence in a timely manner or that it provided insufficient evidence that its Generating Facility continues to meet the Cogeneration Requirements, then the Cogeneration status of the Generating Facility shall be deemed ineffective until such time as Producer again demonstrates to SCE's reasonable satisfaction that the Generating Facility meets the requirements for a Cogeneration facility (the "Cogeneration Status Change").

SCE shall revise its records and the administration of this Agreement to reflect the Cogeneration Status Change and provide Notice to Producer of the Cogeneration Status Change pursuant to Section 9.1 of this Agreement. Such Notice shall specify the effective date of the Cogeneration Status Change. This date shall be the first day of the calendar year for which SCE determines in its sole discretion that the Generating Facility first ceased to meet the Cogeneration Requirements. SCE shall invoice the Producer's Electric Service Account through which the Generating Facility is Interconnected with SCE's Distribution System for Competition Transition Charges ("CTCs") that were not previously billed during the period between the effective date of the Cogeneration Status Change and the date of the Notice in reliance upon Producer's representations that the Generating Facility complied with the Cogeneration Requirements and therefore was eligible for the exemption from CTCs available under Section 372 of the California Public Utilities Code.

Any amounts to be paid or refunded by Producer, as may be invoiced by SCE pursuant to the terms of this warranty, shall be paid to SCE within 30 days of Producer's receipt of such invoice.

**GENERATING FACILITY INTERCONNECTION AGREEMENT**

Multiple Tariffs  
LA COUNTY SANITATION DISTRICT  
NST-312938

---

**APPENDIX F**  
(If Applicable)

**LIST OF ELIGIBLE ACCOUNTS  
TO BE INCLUDED IN NET BILLING TARIFF OR NET ENERGY METERING CALCULATIONS  
PURSUANT TO SCHEDULE BG-NEM OR FC-NEM**

This Appendix F is Not Applicable.

*(Please provide a copy of a recent billing statements for each of the accounts (if any) to be included in this listing. Indicate the priority order you wish SCE to use in applying surplus energy credits.)*

Account Priority <sup>1</sup>	Account Name <sup>2</sup>	Service Address <sup>2</sup>	SCE Service Account Number <sup>2</sup>	SCE Meter Number <sup>2</sup>	SCE TOU Tariff Schedule <sup>2</sup>
1					
2					
3					
4					
5					
6					

Notes:

1. Account Priority: See Load Aggregation provisions of Schedule BG-NEM or FC-NEM. Accounts are listed in priority designated by Producer to receive excess generation credits. The "Host Account," described on page 1 of this agreement, should not be included in this listing.
2. Account information as shown on SCE billing statement.

**GENERATING FACILITY INTERCONNECTION AGREEMENT**

Multiple Tariffs  
LA COUNTY SANITATION DISTRICT  
NST-312938

---

**APPENDIX G**

(If Applicable)

**LIST OF ELIGIBLE ACCOUNTS  
TO BE INCLUDED IN NET BILLING TARIFF OR NET ENERGY METERING AGGREGATION  
CALCULATIONS  
PURSUANT TO SCHEDULES NBT, NEM AND NEM-ST**

This Appendix G is Not Applicable

Primary/Generating Account Name <sup>1</sup>	Service Account No.	Account Address	Annual kWh Load <sup>2</sup>	Estimated Annual kWh Production <sup>3</sup>	Bundled, DA or CCA Service <sup>4</sup>
	3-				

Aggregated Account Name	Service Account No.	Account Address	Annual kWh Load <sup>5</sup>	Bundled, DA or CCA Service <sup>4</sup>
1.	3-			
2.	3-			
3.	3-			
4.	3-			
5.	3-			
6.	3-			
7.	3-			
8.	3-			
9.	3-			
10.	3-			
Please attach additional sheets with aggregated account information, if necessary.				

# GENERATING FACILITY INTERCONNECTION AGREEMENT

Multiple Tariffs  
LA COUNTY SANITATION DISTRICT  
NST-312938

---

## APPENDIX H (If Applicable)

### **PRODUCER WARRANTY AND VERIFIED EQUIPMENT REQUIREMENTS APPLICABLE TO GENERATING FACILITIES REQUESTING INTERCONNECTION PURSUANT TO THE PROVISIONS OF THE NEM SUCCESSOR TARIFFS (i.e., SCHEDULE NBT OR SCHEDULE NEM-ST)**

For Producers interconnecting a Generating Facility under the provisions of Schedule NBT or Schedule NEM-ST, the Generating Facility must have a warranty of at least 10 years for all equipment and the associated installation from the system provider. In appropriate circumstances conforming to industry practice, this requirement may rely on and be satisfied by manufacturers' warranties for equipment and separate contractors' warranties for workmanship (i.e., installation). Warranties or service agreements conforming to requirements applicable to the Self-Generation Incentive Program (SGIP) may also be used for technologies eligible for the SGIP.

For Producers interconnecting a solar Generating Facility under the provisions of Schedule NEM-ST, all major solar system components (including PV panels and other generation equipment, inverters and meters) must be on the verified equipment list maintained by the California Energy Commission ("CEC"). For all NEM-ST Generating Facilities, any other equipment, as determined by SCE, must be verified as having safety certification from a Nationally Recognized Testing Laboratory ("NRTL").

**GENERATING FACILITY INTERCONNECTION AGREEMENT**

Multiple Tariffs  
LA COUNTY SANITATION DISTRICT  
NST-312938

---

**APPENDIX I**  
(If Applicable)

**PRODUCER'S WARRANTY THAT IT MEETS THE REQUIREMENTS FOR AN ELIGIBLE FUEL CELL  
CUSTOMER-GENERATOR AND THE GENERATING FACILITY IS  
AN ELIGIBLE FUEL CELL ELECTRICAL GENERATING FACILITY  
PURSUANT TO SECTION 2827.10 OF THE CALIFORNIA PUBLIC UTILITIES CODE**

This Appendix I is Not Applicable.

Producer has declared that it meets the requirements for an Eligible Fuel Cell customer-generator and the Generating Facility meets the requirements of an "Eligible Fuel Cell Electrical Generating Facility", as defined section 2827.10 of the California Public Utilities Code ("Eligibility Requirements").<sup>1</sup>

Producer warrants that, beginning on the date of Parallel Operation and continuing throughout the term of this Agreement, Producer and the Generating Facility shall continue to meet the Eligibility Requirements. If Producer or the Generating Facility ceases to meet the Eligibility Requirements, Producer shall promptly provide SCE with Notice of such change pursuant to Section 9.1 of this Agreement. If, at any time during the term of this Agreement, SCE determines, in its sole discretion, that Producer or Generating Facility may no longer meet the Eligibility Requirements, SCE may require Producer to provide evidence that Producer and/or the Generating Facility continues to meet the Eligibility Requirements, within 15 business days of SCE's request for such evidence. Additionally, SCE may periodically (typically, once per year) inspect Producer's Generating Facility and/or require documentation from Producer to monitor the Generating Facility's compliance with the Eligibility Requirements. If SCE determines in its sole judgment that Producer either failed to provide evidence in a timely manner or that it provided insufficient evidence that its Generating Facility continues to meet the Eligibility Requirements, then the Eligibility Status shall be deemed ineffective until such time as Producer again demonstrates to SCE's reasonable satisfaction that Producer meets the requirements for an Eligible Fuel Cell customer-generator and/or the Generating Facility meets the requirements for a Eligible Fuel Cell electrical generating facility (the "Eligibility Status Change"). SCE shall revise its records and the administration of this Agreement to reflect the Eligibility Status Change and provide Notice to Producer of the Eligibility Status Change pursuant to Section 9.1 of this Agreement. Such Notice shall specify the effective date of the Eligibility Status Change. This date shall be the first day of the calendar year for which SCE determines in its sole discretion that the Producer and/or Generating Facility first ceased to meet the Eligibility Requirements. SCE shall invoice the Producer for any tariff charges that were not previously billed during the period between the effective date of the Eligibility Status Change and the date of the Notice in reliance upon Producer's representations that Producer and/or the Generating Facility complied with the Eligibility Requirements and therefore was eligible for the rate treatment available under the Net Billing Tariff or Net Energy Metering provisions of SCE's Schedule FC-NEM, Fuel Cell Net Energy Metering.

Any amounts to be paid or refunded by Producer, as may be invoiced by SCE pursuant to the terms of this warranty, shall be paid to SCE within 30 days of Producer's receipt of such invoice.

---

<sup>1</sup> Pursuant to Special Condition 9 of Schedule FC-NEM, Producers who submit all documentation necessary to receive service on Schedule FC-NEM, including the final electrical inspection clearance, after January 1, 2017 but before the California Air Resources Board (CARB) establishes, and the Commission approves as needed, the schedule of annual greenhouse gas (GHG) emissions reduction standards pursuant to Assembly Bill 1637 (Low, 2016) may be subject to the repayment of any interconnection costs, Departing Load charges, Standby charges, and the loss of NEM credits if their Generating Facilities do not meet the standards, once established (expected to be no later than March 31, 2017).



**GENERATING FACILITY INTERCONNECTION AGREEMENT**

Multiple Tariffs  
LA COUNTY SANITATION DISTRICT  
NST-312938

---

**APPENDIX J**  
(If Applicable)

**NET BILLING TARIFF RENEWABLE ELECTRICAL GENERATING FACILITY  
SIZE ATTESTATION**

This Appendix J is Not Applicable

The Renewable Electrical Generating Facility should be sized such that the total annual output in kWh is primarily used to offset the Producer's own annual electrical requirements. For a Producer with a SCE account that has 12 or more months of billing history, the most recent 12 months usage is used to determine the estimated size of the Renewable Electrical Generating Facility.

**1. NBT Renewable Electrical Generating Facility Size Attestation for Existing Service**

Should the Producer elect to oversize their Renewable Electrical Generating Facility (as compared to the 12-month usage history), the following attestation is required when seeking service under Schedule NBT:

By initialing each line in the section below, the Producer attests to the following:

- \_\_\_\_\_ The Renewable Electrical Generating Facility is oversized to meet the Producer's expected increased future electrical usage (i.e., increased usage resulting from an electric vehicle or other electrical appliances to support electrification).
- \_\_\_\_\_ The Renewable Electrical Generating Facility's estimated annual production in kWh is no larger than 150 percent of the Producer's most recent 12 months of total usage.
- \_\_\_\_\_ The Producer expects to increase the electrical usage to correspond with the size of the Renewable Generating Facility within the next year (12 months after receiving Permission to Operate (PTO)).
- \_\_\_\_\_ The Producer has recently increased the electrical usage and the Renewable Electrical Generating Facility's estimated annual production in kWh is no larger than 150 percent of the current projected electrical usage over 12 months. This means that additional electrical usage is planned so that the Renewable Electrical Generating Facility's annual production is not expected to exceed 150 percent of the Producer's current usage projected over the first 12 months after PTO.
- \_\_\_\_\_ The Producer understands that SCE reserves the right to further validate that the Renewable Electrical Generating Facility is sized in accordance with Schedule NBT.

**2. NBT Renewable Electrical Generating Facility Size Attestation for New service or Customers with Less than 12-Months of Usage History**

For a new Producer, or a Producer with less than 12 months of billing history, the following attestation is required when seeking service under Schedule NBT:

By initialing each line in the section below, the Producer attests to the following:

- \_\_\_\_\_ The Generating Facility is sized to meet expected the Producer's future electrical usage.
- \_\_\_\_\_ The Producer expects that the electrical usage will correspond to the size of the Generating Facility within the next year (12 months after receiving Permission to Operate (PTO)).
- \_\_\_\_\_ The Producer understands that SCE reserves the right to further validate that the Generating Facility is sized in accordance with Schedule NBT.